



HAVOCW19X40

19x 40W Zoom Wash Moving Head

USER MANUAL



For your safety, please read this user manual carefully before use.

Event Lighting reserves the right to revise the manual at any time. Information and specifications within this manual are subject to change without notice. Event Lighting assumes no liability or responsibility for any errors or omissions. Please consult Event Lighting for any clarification or information regarding this item.

Version 1.0 (October 2023)

1. Product Introduction:

1.1 Before unpack the fixture, pls make sure that the packing is in good condition, following items will be found in the box:

- The fixture
- This users guide
- 3m DMX cable
- 1.5m power cable with powercon
- Omega bracket for hanging installation
- Safety chain

1.2 Specification

Source

- Light source: 19pcs 40W 4in1 leds, PIXEL control
- Led life: 60.000 hours
- Luminous Flux: 6468 lumen, 110621 lux@3m@4°, 2355 lux@3m@54°
- Control: Remote on/off via DMX
- Ballast: switching mode power supply

Optical System

- Beam angle: 4° to 54°

X/Y

- Pan: 540°(3.32 sec), Tilt: 265° (1.57 sec)
- 16-bit resolution
- Auto repositioning

Features

- DMX channels: 19/26/38/23
- Super fast, smooth and silent movement
- Pixel control of every single led on RGBW separately
- Nice mapping effect with dimming and color fading at the same time
- RGBW four colors mixing to create vivid, saturated and uniform color effect
- Pre-set color temperature at 2800K-10000K,
- Zoom from 4° to 54°
- Full range 0-100% dimmer
- Various strobe
- RDM function to change DMX address, display flip, X/Y Reverse and so on
- Software upgrade via DMX
- Hibernation when lost DMX for preset time
- Indicate temperature info of base
- Fan speed auto change according to temperature
- Heat pipe for cooling

Display

- 2.4inch super nice LCD display with friendly English/ Chinese/French/Spanish menu
- Auto lock and flip
- Flip

1.3 Description of the Device



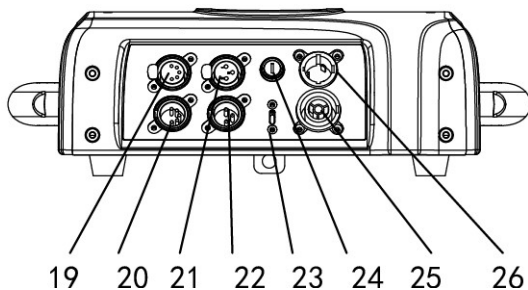
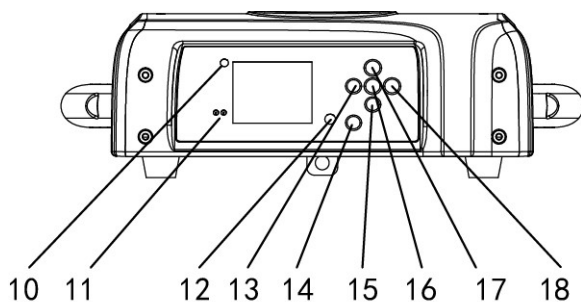
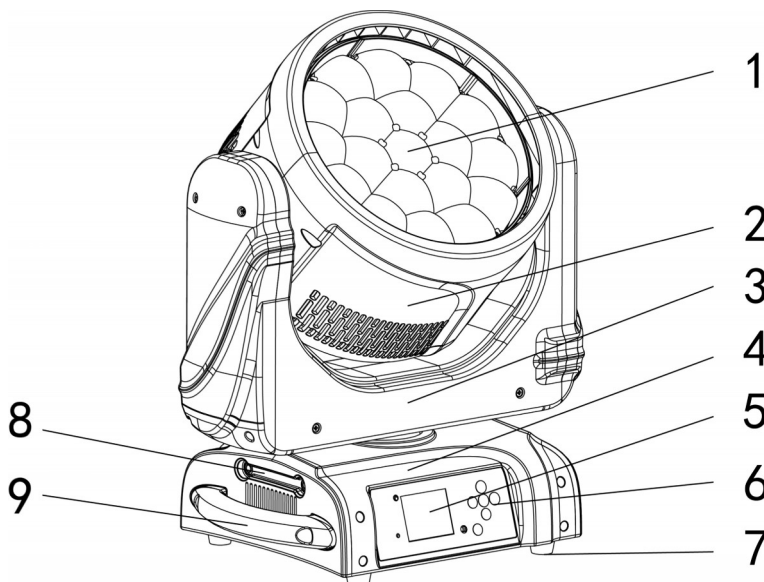











1. Project lens
2. Head
3. Arm
4. Base
5. Display
6. Operation button
7. Foot stand
8. Antenna
9. Handle



10. Battery indicator
11. Ethernet indicator
12. Power indicator
13. Left button
14. Power button
15. Down button
16. Enter button
17. Up button
18. Right button
19. 5-pin DMX in
20. 5-pin DMX out
21. 3-pin DMX in
22. 3-pin DMX out
23. USB
24. Fuse
25. Powercon out
26. Powercon in

2. Safety and maintenance Information

2.1 Safety Info

	Before operate this unit, please carefully read this users guide and keep if needed in future. It's necessary to respect following rules.
	The disposal of the device after lifecycle could damage the environment, need to take it to special company for recycling or return to authorized dealer.
	The products referred to in this manual conform to the European Community Directives and are therefore marked with CE logo.
	Keep this device away from children and unauthorized users, the manufacturer will not take responsibility for the damage due to any disregard of the information provided in this manual and wrong operation.
	Before operate the device, pls make sure the fixture is in good housing, ensure pan and tilt can rotate in its complete range.
	Pls make sure minimal 0.3m distance need to kept between the fixture to any flammable material.
	The device can only run with 100-240v voltage, 50/60Hz power, don't connect to any other wrong power. Disconnect the device from main power before open the shield or maintenance.
	The device is designed only for indoor usage, pls keep it away from moisture. Do not expose the device under the sun or directly to any other lighting source.
	Never look directly into the projecting lens when the fixture is power on, the light may trigger epileptic seizures in photosensitive persons or persons with epilepsy. Especially at beam effect, extreme caution and observance of these safety instructions is mandatory.
	Don't put or install the device on a surface that subject to vibration or bumps.
Ta=45°C	The device is supposed to work in the temperate range -15° C and +45° C, do not use the device when the temperate exceed this range.
	The lens, shield need to be replaced when obviously broken, never use the device when the shield is not completed closed.
	Safety I class device, need to be earth connected.
	When the fixture is hanged overhead, the safety rope must be fixed to the bottom of the device to the appropriate fixing point.
	Always carry the device by the handles, do not take the head or arm directly for transportation.

2.2 Maintenance

2.2.1 Operation only allowed to qualified person, damages due to unprofessional operation or remove of any parts inside will not be considered in warranty service. There are no serviceable parts inside the device or package, service only leaves to authorized dealers.

2.2.3 Never allow the optical components contact with oil, fat or any other liquid.

2.2.4 A regular clearance of the device is needed for long-term usage, this is very helpful to maintain the lifetime and brightness need to use a soft and lint-free cloth to clean the optical system, fan and air flowing tunnel.

2.2.5. Trouble Shooting

Problems	Possible reasons	Checking or solutions
Device not power up	Powercon or power cable damaged Faulty power supply	Change a good power cable to try Replace new power supply
Pan/Tilt error or vibrate	Faulty Pan/Tilt PCB Faulty opto sensor Cable loosen	Replace PT012A PCB Replace opto sensor OP005 Check the cable connect to OP005
LED off	Temperature protection Fan not working Faulty LED Dimmer and strobe set at 0 Faulty power supply	Check the temperature from menu Check the fan speed info from menu Replace new LED Set dimmer and strobe channel at 255 Replace new power supply
Device not response to DMX	Faulty display PCB Wrong DMX addressing Faulty DMX cable	Replace new display PCB Check the address and setting Change to a good DMX cable

2.2.6 Replacement of the fuse

Need to replace with same type and rating, which originally installed in the device.

Step One: Unplug power cable from main power.

Step Two: Unscrew the fuse holder out of the housing with a screwdriver.

Step Three: Remove the broken fuse and replace with an exact same type of new fuse.

Step Four: Insert the fuse holder back to the housing and screw tight and reconnect power.

3. Installation

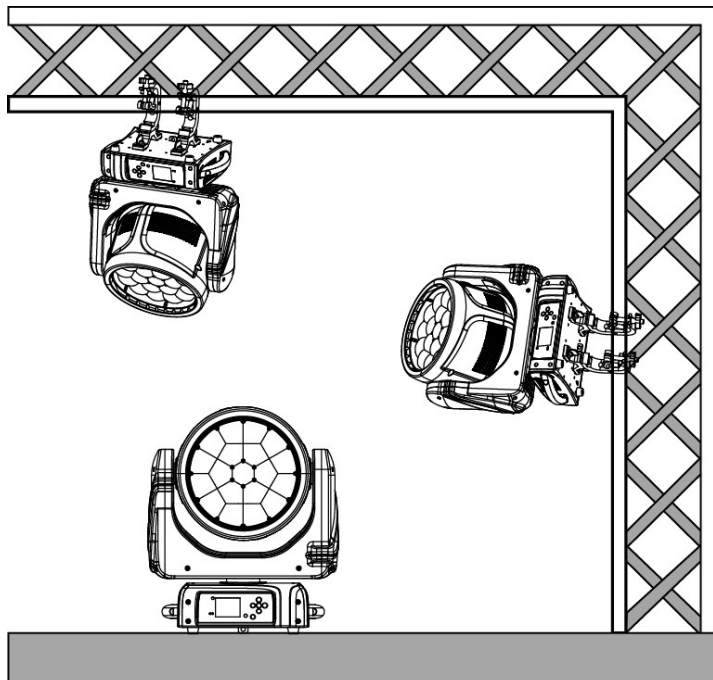

3.1 The device could be either put on a solid and even surface, or mounted upside down or sideways like left picture.

3.2 The mounting place must be sufficient stable and be able to support a weight of 10 times of the unit's weight. When the fixture is hanged, always additionally secure the device with the safety chain, fasten the safety rope at a suitable position so that the maximum fall of the projector will be 20 cm

3.3 How to do mounting installation.

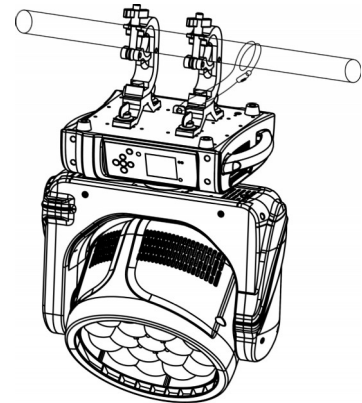
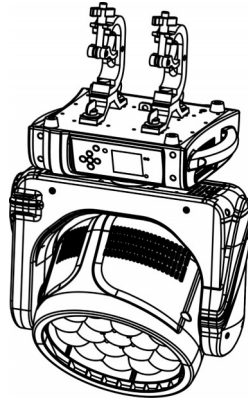
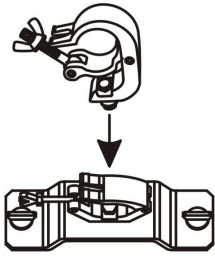

Step one: Installation the clamp onto the omega bracket;

Step two: Install the clamp and bracket on the bottom of panel, fasten the quick-locks;

Step three: Install the whole device onto appropriate truss and fasten the clamps, tight the safety rope with the truss or other fixing point at a suitable position that drop down distance not exceed 20 cm.

4. Control menu

4.1 Meaning of the icon in menu

CONNECT	LIGHT	INFOMATION	SET	PROGRAM
				

4.2 Menu tree

Default setting shadowed. Mark with ① can be basic reloaded, ② be program reloaded, ③ can be private reloaded.

CONNECT	ADDRESS	FIXTURE	VALUE (1-512)①(001)		
		PIXELS	VALUE (1-512)①(001)		
	CONTROL PROTOCOL	FIXTURE	DMX/W-DMX		
		PIXELS	FOLLOW FIXTURE/DMX/W-DMX		
	DMX MODE	FIXTURE	BASIC/STANDARD/EXTENDE D		
		PIXELS	OFF/RING/PIXELS		
	WIRELESS	WDMX ON/OFF	ON/OFF		
		WDMX MODE	TRANSMITTER/RECEIVER		
		TX LINK	ON/OFF		
		TX UNLINK	ON/OFF		
RX RESET		ON/OFF			

		IN TO WDMX	OFF/FIX TO WDMX/PIX TO WDMX		
		WDMX TO DMX	ON/OFF		
Setup	FIXTURE SETTINGS	DMX FAULT	HOLD/BLACKOUT		
		TEMPERATURE UNIT	Fahrenheit /Celsius		
		FAN MODE	AUTO/HIGH/SILENT		
		DIMMER CURVE	LINEAR/S-CURVE/SQUARE LAW/ INVERSE SQUARE LAW		
		DIMMER SPEED	AUTO/FAST/MEDIUM/SLOW		
		LED FREQUENCY	600HZ/1200 HZ/2000 HZ/4000 HZ/6000HZ/25KHZ/50KHz		
		MENU LANGUAGE	En/Fr/Sp/简/繁 (En)		
		TRANSFER CONFIGURATION	WITHOUT DMX ADDRESS		
			WITH DMX ADDRESS		
		WHITE CALIBRATION	OFF/STUDIO		
		Tungsten emulation	ON/OFF		
	INVERT MAPPING	ON/OFF			
	MOVEMENT	PAN REVERSE	ON/OFF		
		TILT REVERSE	ON/OFF		
		PAN/TILT FEEDBACK	ON/OFF		
		PAN/TILT MODE	SLOW/MEDIUM/FAST		
TOTEM MODE		OFF/UP/DOWN			
SCREEN	BACKLIGHT	ON/10S/20S/30S			
	FLIP DISPLAY	ON/OFF/AUTO			
	KEY LOCK	ON/OFF			
INFORMATION	FIXTURE HOURS	TOTAL	(ONLY READ)		
		PARTIAL	(READ AND RESET)		
	CURRENT HOURS	TOTAL	(ONLY READ)		
		PARTIAL	(READ AND RESET)		
	LED HOURS	TOTAL	(ONLY READ)		
		PARTIAL	(READ AND RESET)		
POWER ON	TOTAL	(ONLY READ)			

		CYCLE	PARTIAL	(READ AND RESET)		
	TEMPERATURE	NEAR SOURCE TEMP, DRIVER PCB TEMP, LED PCB TEMP,...				
	FAN SPEED	NEAR SOURCE FAN, BASE FAN,...				
	CHANNEL VALUE	PAN...				
	ERROR MESSAGE	PAN, TILT...				
	FIXTURE MODEL	XXXXXXXXXX				
	RDM UID	(READ AND RESET)				
	SOFTWARE VERSION	1U01 V1.0.00...				
SERVICE	RESET	ALL				
		PAN & TILT				
		...				
	CALIBRATION	PASSWORD				
		PAN				
		...				
	MANUAL CONTROL	PAN				
		...				
	RELOAD DEFAULT	BASIC RELOAD		ON/OFF		
		PROGRAM RELOAD		ON/OFF		
		Password				
		FACTORY RELOAD		ON/OFF		
Program	Play①	DMX Receive				
		Slave Receive	Slave Receive 1,2,3			
		Sequence	Master / Alone			
		Music	Master / Alone			
		Mic Sens	0%~100%			
	Select Chase②	Chase Part 1	Chase 1 ~ 8 Chase 1			
		Chase Part 2	Chase 1 ~ 8 Chase 2			
		Chase Part 3	Chase 1 ~ 8 Chase 3			
	Edit Chase②	Chase 1	Chase Test			
		:	Step 01			=XX X
		Chase 8	Step 64			=XX X

Edit Scenes②	Edit Scene 001	Pan,Tilt,.....	=XX X
	~ Edit Scene 250	--Fade Time--	=XX X
		--Secne Time--	=XX X
		DMX Input	
Scenes Record	ScXX=>ScXX		

5. DMX connection and DMX protocol

5.1 DMX addressing:

5.1.1 The device is controlled by universal DMX 512 protocol, DMX address is the start channel used to receive instructions from the external controller. For independent control, each fixture must be assigned its unique address control channels. For example, this device has four channel modes: 19/26/38/23, if we set the mode at standard 19 channels mode, and there are several models need to be independently controlled, we just simply address first fixture at 1, and second fixture at 20, third one at 39, etc.

If the devices have the same address, they will behave synchronically.

DMX addressing is limited, don't set the address so high that without enough control channels for the fixtures.

Display is flashing when no DMX signal is received.

5.1.2 This device is equipped with 3-pins and 5-pins DMX in and out sockets only.



5.1.3 The termination is prepared by soldering a 120Ω resistor between pins 2 and 3.

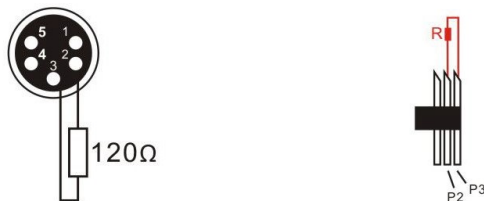

5.1.4 Connection: use DMX cable with 3+5 pin XLR-plugs to connect the controller with the fixture or one fixture with ano

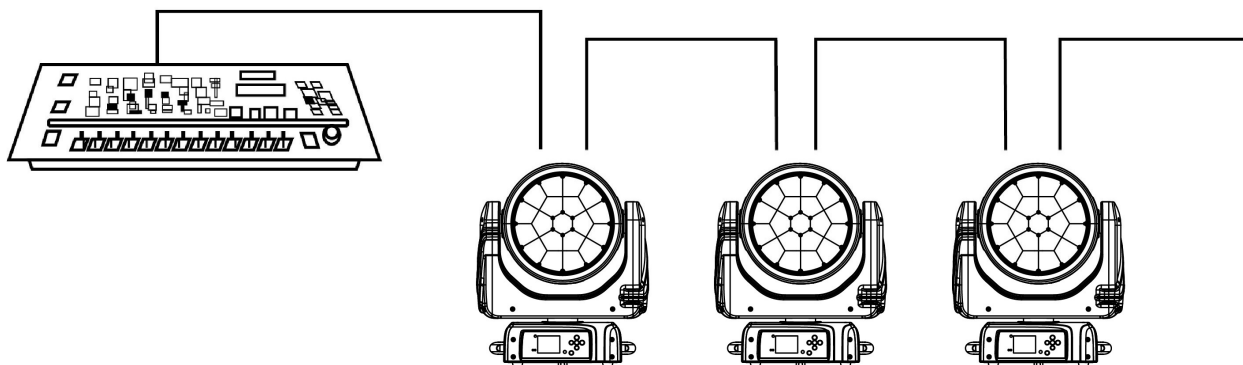

5.2 DMX chart

Channel							name	function	Min DMX	Max DMX
V1.0.00										
Main Engine				Pixel Engine						
Basic	STD	EXT	Basic 2	OFF	Ring	Pixel				
1	1	1	1				Pan	Pan Coarse	0	255
2	2	2	2				Pan Fine	Pan Fine	0	255
3	3	3	3				Tilt	Tilt Coarse	0	255
4	4	4	4				Tilt Fine	Tilt Fine	0	255
5	5	5	5				XY Speed	fastest to Slowest	0	255
6	6	6	6				Dimmer	Dimmer(0->100%)	0	250
7	7	7	7				Dimmer Fine	Dimmer Fine(0->100%)	0	255
8	8	8	8				Shutter/Strobe	Close	0	1
								Strobe from slow to fast	2	62
								Open	63	64
								Pulse in from slow to fast	65	125
								Open	126	127
								Pulse out from slow to fast	128	188
								Open	189	190
								Randon from slow to fast	191	251
Open	252	255								
9	9	9	9				Red	Red	0	255
	10	10	10				Red Fine	Red Fine	0	255
10	11	11	11				Green	Green	0	255

	12	12	12				Green Fine	Green Fine	0	255
11	13	13	13				Blue	Blue	0	255
	14	14	14				Blue Fine	Blue Fine	0	255
12	15	15	15				White	White	0	255
	16	16	16				White Fine	White Fine	0	255
13	17	17	17				Color Macro	Color Macro	0	255
14	18	18					CTO	lineary from 2800K to 10000K	0	255
			18				CTO	Close	0	1
								lineary from 2800K to 10000K	2	255
15	19	19	19				Zoom	0 - 100%	0	255
	20	20	20				Zoom Fine	0 - 100%	0	255
16	21	21					Crossfade from Arnet to Klingnet	0 - 100%	0	255
17	22	22					Crossfade for Pixel Engine	0 - 100%	0	255
18	23	23					Crossfade from White to Color	0 - 100%	0	255
								No Function/Safe	0	1
								Reserved	2	3
								Reserved	4	5
								PAN REVERSE ON	6	7
								PAN REVERSE OFF	8	9
								TILT REVERSE ON	10	11
								TILT REVERSE OFF	12	13
								PAN/TILT MODE FAST	14	15
								PAN/TILT MODE MEDIUM	16	17
								PAN/TILT MODE SLOW	18	19
								MOVEMENT IN BLACKOUT ON	20	21
								MOVEMENT IN BLACKOUT OFF	22	23
19	24	24	21				Control	HOME POSITION STANDARD	24	25
								HOME POSITION CUSTOM	26	27
								DISPLAY ON	28	29
								DISPLAY 10S	30	31
								DISPLAY 20S	32	33
								DISPLAY 30S	34	35
								FLIP DISPLAY ON	36	37
								FLIP DISPLAY OFF	38	39
								FLIP DISPLAY AUTO	40	41
								KEY LOCK ON	42	43
								KEY LOCK OFF	44	45
								FAN MODE AUTO	46	47

							FAN MODE SILENT	48	49
							FAN MODE HIGH	50	51
							WHITE CALIBRATION OFF	52	53
							WHITE CALIBRATION STUDIO	54	55
							Tungsten emulation on	56	57
							Tungsten emulation off	58	59
							NO SIGNAL HOLD	60	61
							NO SIGNAL BLACKOUT	62	63
							Reserved	64	65
							Reserved	66	67
							DIMMER CURVE LINEAR	68	69
							DIMMER CURVE S-CURVE	70	71
							DIMMER CURVE SQUARE LAW	72	73
							DIMMER CURVE INVERSE SQUARE LAW	74	75
							DIMMER SPEED AUTO	76	77
							DIMMER SPEED FAST	78	79
							DIMMER SPEED MEDIUM	80	81
							DIMMER SPEED SLOW	82	83
							LED FREQUENCY 600HZ	84	85
							LED FREQUENCY 1200HZ	86	87
							LED FREQUENCY 2000HZ	88	89
							LED FREQUENCY 4000HZ	90	91
							LED FREQUENCY 6000HZ	92	93
							LED FREQUENCY 25KHZ	94	95
							LED FREQUENCY 50KHZ	96	97
							INVERT MAPPING ON	98	99
							INVERT MAPPING OFF	100	101
							RESET ALL	102	103
							RESET PAN/TILT	104	105
							RESET ZOOM	106	107
							Reserved	108	253
							FACTORY DEFAULT OF CONTROL FUNCTIONS	254	255
	25	25	22				CTO on colors	0 - 100%	0 255
	26	26	23				Tint	-25	0 127
				0	128 128				
				+25	129 255				
	27					Pattern	No FX	0 16	

							FX 1	17	22
							FX 2	23	28
							FX 3	29	34
							FX 4	35	40
							FX 5	41	46
							FX 6	47	52
							FX 7	53	58
							FX 8	59	64
							FX 9	65	70
							FX 10	71	76
							FX 11	77	82
							FX 12	83	88
							FX 13	89	94
							FX 14	95	100
							FX 15	101	106
							FX 16	107	112
							FX 17	113	118
							FX 18	119	124
							FX 19	125	130
							FX 20	131	136
							FX 21	137	142
							FX 22	143	148
							FX 23	149	154
							FX 24	155	160
							FX 25	161	166
							FX 26	167	172
							FX 27	173	178
							FX 28	179	184
							FX 29	185	190
							FX 30	191	196
							FX 31	197	202
							FX 32	203	208
							FX 33	209	214
							FX 34	215	220
							FX 35	221	226
							FX 36	227	232
							FX 37	233	238
							FX 38	239	244
							FX 39	245	250
							FX 40	251	255
		28					Indexing	0	127
						Pattern Speed	CW from fast to slow	128	190
							Stop	191	192
							CCW from slow to fast	193	255
		29				Pattern Fade	0 - 100%	0	255
		30				Pattern Transition	0 - 100%	0	255

		31				Foreground Intensity	0 - 100%	0	255
		32				Foreground Strobe	See Shutter/Strobe Channel	0	255
		33				Background Intensity	0 - 100%	0	255
		34				Background Strobe	See Shutter/Strobe Channel	0	255
		35				Background Red	0 - 100%	0	255
		36				Background Green	0 - 100%	0	255
		37				Background Blue	0 - 100%	0	255
		38				Background White	0 - 100%	0	255
					1	Ring 1 Red	0 - 100%	0	255
					2	Ring 1 Green	0 - 100%	0	255
					3	Ring 1 Blue	0 - 100%	0	255
					4	Ring 1 White	0 - 100%	0	255
					5	Ring 2 Red	0 - 100%	0	255
					6	Ring 2 Green	0 - 100%	0	255
					7	Ring 2 Blue	0 - 100%	0	255
					8	Ring 2 White	0 - 100%	0	255
					9	Ring 3 Red	0 - 100%	0	255
					10	Ring 3 Green	0 - 100%	0	255
					11	Ring 3 Blue	0 - 100%	0	255
					12	Ring 3 White	0 - 100%	0	255
					1	Red 1	0 - 100%	0	255
					2	Green 1	0 - 100%	0	255
					3	Blue 1	0 - 100%	0	255
					4	White 1	0 - 100%	0	255
					5	Red 2	0 - 100%	0	255
					6	Green 2	0 - 100%	0	255
					7	Blue 2	0 - 100%	0	255
					8	White 2	0 - 100%	0	255
					9	Red 3	0 - 100%	0	255
					10	Green 3	0 - 100%	0	255
					11	Blue 3	0 - 100%	0	255
					12	White 3	0 - 100%	0	255
					...		0 - 100%	0	255
					73	Red 19	0 - 100%	0	255
					74	Green 19	0 - 100%	0	255
					75	Blue 19	0 - 100%	0	255
					76	White 19	0 - 100%	0	255

6. Unique Features

6.1 RDM, stand for “Remote Device Management”, with this function, users can realize remote control of the device, such as remotely changing DMX address, reverse pan/tilt setting, check a lot of useful information such as temperature, power consumption, fan speed. Etc. Every single device has a unique RDM code before left factory to distinguish from each other, usually not suggest users change this code freely.

6.2 Software upgrade function via DMX cable, if there is any new firmware for this device come out, it can be upgraded simply via a software upgrade box, no need to change any mechanical parts. The upgrade box is not included in the package, if need any further assistance pls just contact authorized dealers.

6.3 Hibernation, the device will enter sleeping mode if activated after a period of disconnecting DMX signal to save the power consumption, and will return immediately as soon as the DMX signal is sent again.

6.4 Display battery, this function is prepaid in the display PCB, users just need to install a normal 10440 600mAh 3.7V rechargeable lithium battery, then users could power on the display and do setting without connect to main power.

6.5 Display flip, by press up and down button for more than 3 seconds, the display will flip automatically, this function is useful to read menu conveniently when device is hanged.

7. Dimensions Drawing

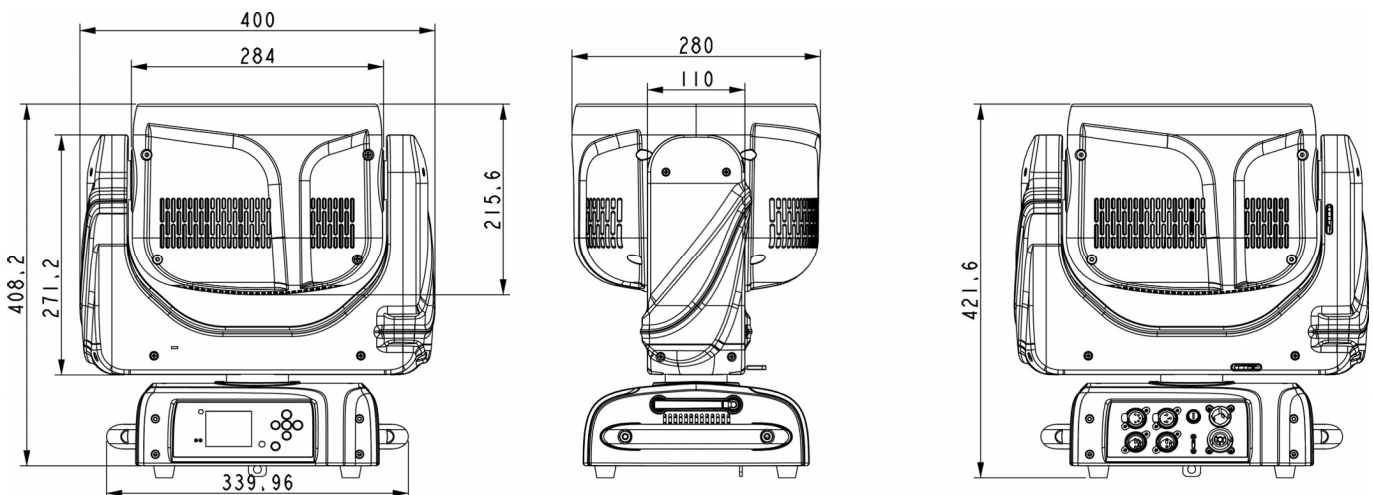

8. Technical specification

Power supply	100-240 V AC, 50/60 Hz ~
Power consumption	560W
LED	19pcs 40W 4in1 leds
DMX channels	19/26/38/23 ch
Beam angle	4° - 54°
Luminous flux	6468 lumen, 110621 lux@3m@4°, 2355 lux@3m@54°
Fuse	T 8 A, 250 V
Device dimensions	400*421*280mm
Net Weight	15.5KG

Warranty

Please refer to your local dealer or contact Event Lighting.

www.event-lighting.com.au